

# ACTION 500 *series*



## ACTION-515A

---

DAS Audio Group, S.L. - C/ Islas Baleares 24 - 46988  
Fuente del Jarro - Valencia - Spain - Tel. +34961340860  
Updated (DD/MM/YYYY): 14/10/2024



SOUND WITH SOUL

## KEY FEATURES

- Active biamp system
- Dual-channel 1000 W<sub>peak</sub> Class D amplifier
- Birch plywood enclosure
- Durable ISO-flex paint
- DAScontrol™ interface for easy setup and adjustment
- DSP with presets and LCD screen

## DESCRIPTION

ACTION-515A is an active system designed to deliver a highly versatile solution, from fixed installations to the popular portable PA application. Its rotatable horn with 90° x 60° dispersion means the enclosure can be used horizontally in a fixed installation, as a stage monitor or even as front fill.

As part of our company culture, all our systems are developed under a single philosophy: to deliver the highest possible quality in terms of both materials and overall system design. In the ACTION-500 series we use the same birch plywood as our touring systems for a tight, natural warm sound found nowhere else on the market. The series' full range of active tops is complete with two balanced XLR inputs for mic and line, an additional 3.5 mm mini jack input, and a powerCON connection.

The system has a 15MI4 loudspeaker for a more powerful low-frequency response than other tops in the series and an M-34 compression driver for high frequencies which, together with the 1000 W<sub>peak</sub> Class D amplifier, deliver outstanding performance. The DAScontrol™ interface uses a high-range 24-bit DSP and rear LCD screen to enable the selection of presets, EQ modes, delay, gain control and signal source mix.

# ACTION-515A

---

DAS Audio Group, S.L. - C/ Islas Baleares 24 - 46988  
Fuente del Jarro - Valencia - Spain - Tel. +34961340860  
Updated (DD/MM/YYYY): 14/10/2024



SOUND WITH SOUL

## SPECIFICATIONS

### Performance

Frequency Range (-10 dB)	45 Hz - 20 kHz
Horizontal Coverage (-6 dB)	90°
Vertical Coverage	60°
Maximum Peak SPL at 1 m	131 dB

### Electronics and Connectors

Nominal Amplifier Power (continuous)	500 W
Nominal Amplifier Power (peak)	1000 W
Input Type	Balanced
Input Impedance	20 kohms
Input Sensitivity	1.95 V (+8 dBu)
Audio Signal Input Connector	2 x Female XLR
AUX Input	1 x 3.5 mm Mini Jack
Audio Signal Loop Thru Connector	1 x Male XLR
Control	DAScontrol™
Current Draw 230 V / 115 V	1.1 A / 2.2 A

### Enclosure

Enclosure Construction	Birch Plywood
Enclosure Geometry	Trapezoidal
Rigging	M10 Rigging Points
Finish	ISO-flex Paint
Color	Black

# ACTION-515A

DAS Audio Group, S.L. - C/ Islas Baleares 24 - 46988  
Fuente del Jarro - Valencia - Spain - Tel. +34961340860  
Updated (DD/MM/YYYY): 14/10/2024



Dimensions ( H x W x D ) 720 x 445 x 385 mm  
28,3 x 17,5 x 15,2 in

Net Weight 23,5 kg ( 51,8 lb )

### Components

LF Driver 15M14

HF Driver M-34

Horn/Waveguide BC-916

### Shipping

Carton Dimensions ( H x W x D ) 785 x 430 x 505 mm  
30,9 x 16,9 x 19,9 in

Shipping Weight 26,5 kg ( 58,4 lb )

## DIMENSIONS

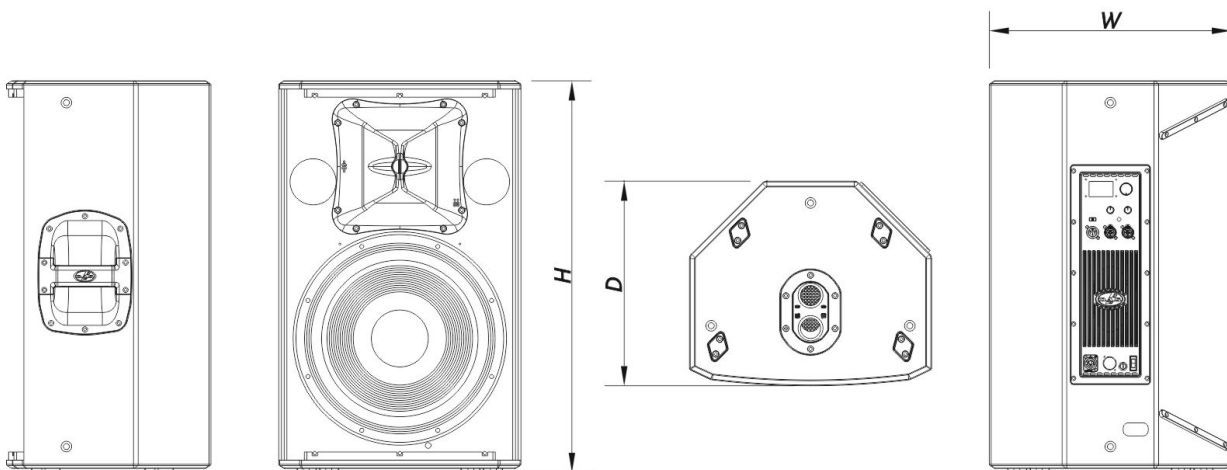

Model

Description

P/N

# ACTION-515A

DAS Audio Group, S.L. - C/ Islas Baleares 24 - 46988  
Fuente del Jarro - Valencia - Spain - Tel. +34961340860  
Updated (DD/MM/YYYY): 14/10/2024



SOUND WITH SOUL

## ORDERING INFORMATION

### System

ACTION-515A	10427250
-------------	----------

### Replacement Parts

15MI4	Cone Transducer	10214300
BC-916	Horn	30006590
DSP-ACTION-515A	Dsp	20406594
GM-15MI4	Recone Kit	20208280
GM-M34	Diaphragm	20205060
M-34	Compression Driver	10207080
MP-ACT515A	Power Module	20406584
ORBIT300+100UM	Amplifier	30007231

### Accessories

ANL-2	Rigging Accessories	10101020
FUN-VT15	Transport Accessories	10103720
TRD-6	Installation & Stacking Acc.	10104470
TRD-7	Installation & Stacking Acc.	10104471
TRPD-S2-PAK	Installation & Stacking Acc.	10104011

## PERFORMANCE DATA

# ACTION-515A

DAS Audio Group, S.L. - C/ Islas Baleares 24 - 46988  
Fuente del Jarro - Valencia - Spain - Tel. +34961340860  
Updated (DD/MM/YYYY): 14/10/2024



SOUND WITH SOUL

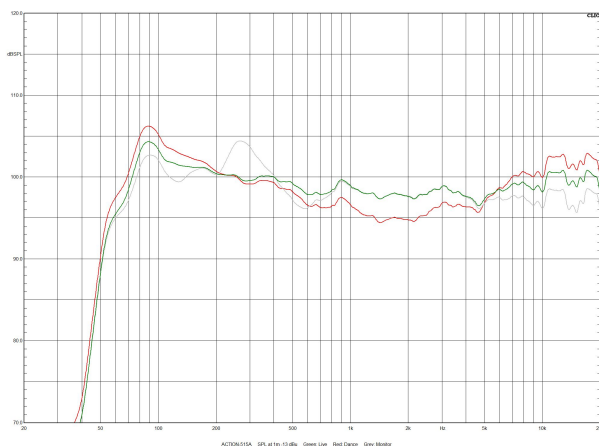

Frequency Response Curve

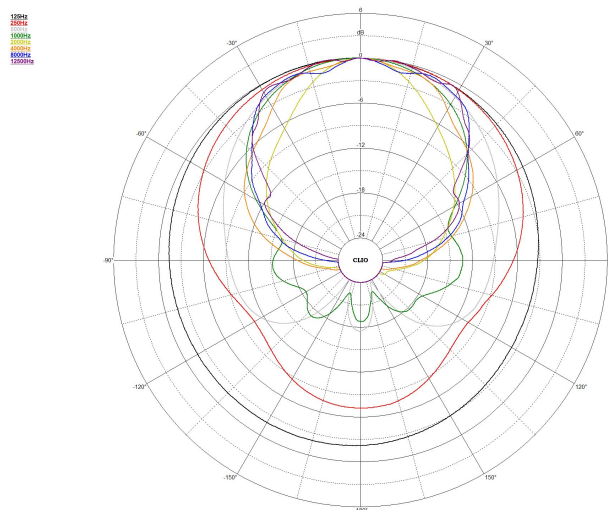

Horizontal Polar Plot

# ACTION-515A

DAS Audio Group, S.L. - C/ Islas Baleares 24 - 46988  
 Fuente del Jarro - Valencia - Spain - Tel. +34961340860  
 Updated (DD/MM/YYYY): 14/10/2024



SOUND WITH SOUL

120Hz  
200Hz  
500Hz  
1000Hz  
2000Hz  
4000Hz  
8000Hz  
12000Hz

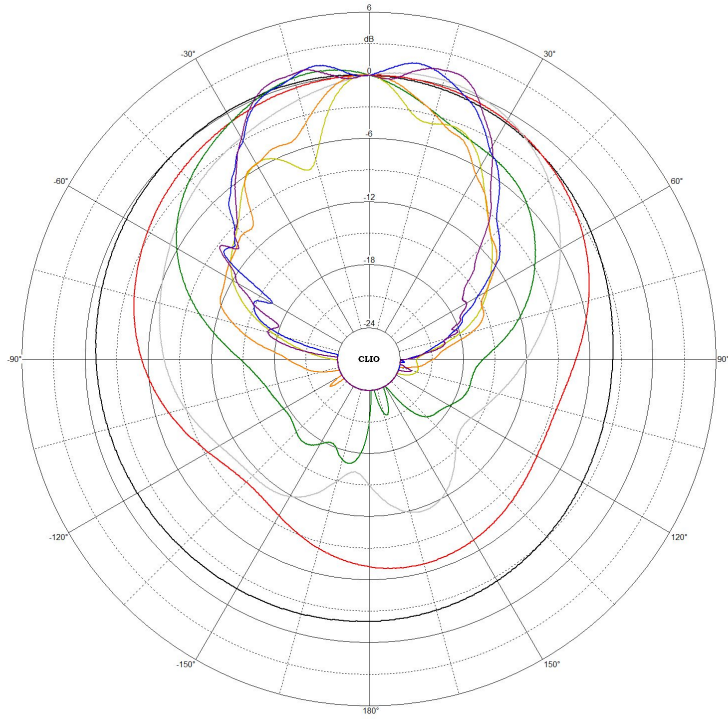

# ACTION-515A

DAS Audio Group, S.L. - C/ Islas Baleares 24 - 46988  
Fuente del Jarro - Valencia - Spain - Tel. +34961340860  
Updated (DD/MM/YYYY): 14/10/2024



SOUND WITH SOUL