

special applications



# BIDRIVER-PLUS-T

---

DAS Audio Group, S.L. - C/ Islas Baleares 24 - 46988  
Fuente del Jarro - Valencia - Spain - Tel. +34961340860  
Updated (DD/MM/YYYY): 30/07/2024



SOUND WITH SOUL

## KEY FEATURES

- 2-way, mid-high unit
- Coaxial speaker built into a special horn unit
- High sensitivity and exceptional control of directivity
- Ideal for "long-throw" applications

## DESCRIPTION

The BIDRIVER-PLUS-T is comprised of a coaxial loudspeaker which incorporates a 10" cone transducer with a 4" voice coil. The massive magnet structure and top plates provide efficient heat evacuation for low power compression. The high frequency unit incorporates a 4" titanium diaphragm and voice coil assembly. The aluminum phase corrector guarantees coherent and linear frequency response. The BIDRIVER-PLUS-T can be used successfully in applications requiring high intelligibility of the human voice and music reproduction not requiring bass reinforcement. The unit is capable of developing high sound pressure levels covering large distances with a clear and defined reproduction of the message. It is especially adequate for large open areas requiring a "long throw". The BIDRIVER-PLUS-T Plus T is equipped with a line transformer for distributed systems and is designed to comply with the IP54 standards for outdoor use.

# BIDRIVER-PLUS-T

---

DAS Audio Group, S.L. - C/ Islas Baleares 24 - 46988  
Fuente del Jarro - Valencia - Spain - Tel. +34961340860  
Updated (DD/MM/YYYY): 30/07/2024



SOUND WITH SOUL

## SPECIFICATIONS

### Performance

Frequency Range (-10 dB)	160 Hz – 12 kHz
Horizontal Coverage (-6 dB)	60°
Vertical Coverage	55°
Nominal Impedance	8 ohms
Transformer Taps 70 V	75 W
Transformer Taps 100 V	150 W
RMS Power Handling	300 W
Peak Power Handling	1200 W
On-axis Sensitivity 1W/1 m	104 dB SPL
Recommended Amplifier	INTEGRAL-A1002 INTEGRAL-A1004

### Connectors

Audio Input Connector	Covered Barrier Strip Terminals
Audio Output Connector	Covered Barrier Strip Terminals

### Enclosure

Enclosure Construction	Polyurethane
Color	Black
Depth	405 mm (15,9 in)
Dimensions ( H x W x D )	400 x 450 x 405 mm 15,7 x 17,7 x 15,9 in
Net Weight	17,7 kg ( 39,0 lb )

# BIDRIVER-PLUS-T

DAS Audio Group, S.L. - C/ Islas Baleares 24 - 46988  
Fuente del Jarro - Valencia - Spain - Tel. +34961340860  
Updated (DD/MM/YYYY): 30/07/2024



SOUND WITH SOUL

## Components

LF Driver	CX-104
Horn/Waveguide	D-BID-6055

## Shipping

Carton Dimensions ( H x W x D )	490 x 420 x 505 mm 19,3 x 16,5 x 19,9 in
Shipping Weight	23,7 kg ( 52,3 lb )

## DIMENSIONS

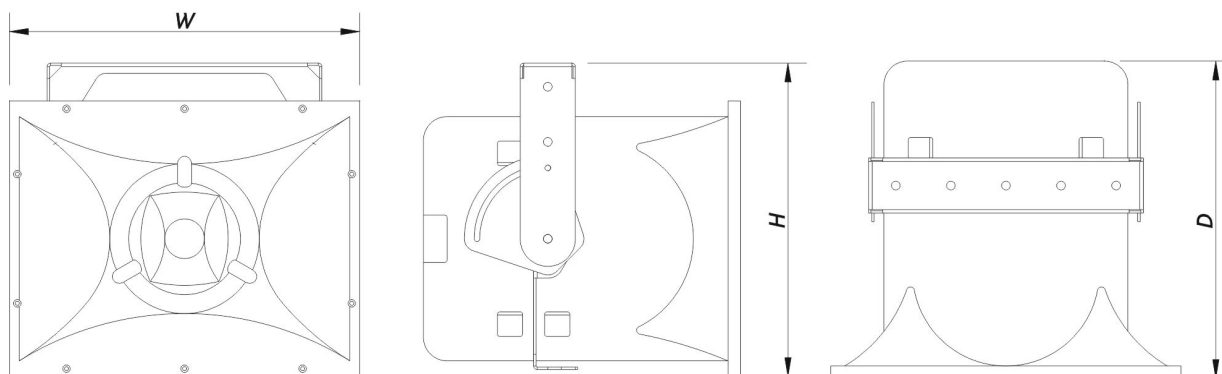

## ORDERING INFORMATION

Model	Description	P/N
<b>System</b>		
BIDRIVER-PLUS-T		10413030
<b>Replacement Parts</b>		
CX-104	Transducer	20208960

# BIDRIVER-PLUS-T

DAS Audio Group, S.L. - C/ Islas Baleares 24 - 46988  
Fuente del Jarro - Valencia - Spain - Tel. +34961340860  
Updated (DD/MM/YYYY): 30/07/2024



D-BID-6055	Horn	30003496
F-BIDRIVER	Filter	31000226
GM-CX10	Recone Kit	20202010
GM-K8H	Diaphragm	20204020

# BIDRIVER-PLUS-T

---

DAS Audio Group, S.L. - C/ Islas Baleares 24 - 46988  
Fuente del Jarro - Valencia - Spain - Tel. +34961340860  
Updated (DD/MM/YYYY): 30/07/2024



SOUND WITH SOUL