

artec 500 series



ARTEC-S15A-W-230

DAS Audio Group, S.L. - C/ Islas Baleares 24 - 46988
Fuente del Jarro - Valencia - Spain - Tel. +34961340860
Updated (DD/MM/YYYY): 13/10/2024



SOUND WITH SOUL

KEY FEATURES

- Powered subwoofer system
- High output 15" loudspeaker
- Loop Thru connections
- Filtered output defeat switch
- Variable LPF range 100-138 Hz

DESCRIPTION

The Artec-S15A is a powered subwoofer system designed to provide extended bass response for the Artec-full range cabinets. A 2000 Wpeak Class D amplifier drives a D.A.S. 15SX bass loudspeaker. The 15SX loudspeaker incorporates a 4" voice coil for high power handling and output. The subwoofer system includes two balanced inputs with stereo filtered output connections for Artec-satellite systems. The variable LPF ranges from 100 Hz 138 Hz.

ARTEC-S15A-W-230

DAS Audio Group, S.L. - C/ Islas Baleares 24 - 46988
Fuente del Jarro - Valencia - Spain - Tel. +34961340860
Updated (DD/MM/YYYY): 13/10/2024



SOUND WITH SOUL

SPECIFICATIONS

Performance

Frequency Range (-10 dB)	45 Hz -138 Hz
Maximum Peak SPL at 1 m	134 dB

Electronics and Connectors

Nominal Amplifier Power (continuous)	1000 W
Nominal Amplifier Power (peak)	2000 W
Input Type	Balanced
Input Impedance	20 kohms
Input Sensitivity	1.95 V (+8 dBu)
Audio Signal Input Connector	2 x Female XLR
Audio Signal Loop Thru Connector	2 x Male XLR
AC Output Connector	powerCON NAC3FCB
Current Draw 230 V / 115 V	2.0 A/-

Enclosure

Enclosure Construction	Birch Plywood
Enclosure Geometry	Rectangular
Rigging	M10 Rigging Points
Finish	ISO-flex Paint
Color	White
Dimensions (H x W x D)	515 x 465 x 585 mm 20,3 x 18,3 x 23,0 in
Net Weight	31,0 kg (68,3 lb)

ARTEC-S15A-W-230

DAS Audio Group, S.L. - C/ Islas Baleares 24 - 46988
Fuente del Jarro - Valencia - Spain - Tel. +34961340860
Updated (DD/MM/YYYY): 13/10/2024



SOUND WITH SOUL

Components

LF Driver	15LXN
-----------	-------

Shipping

Carton Dimensions (H x W x D)	580 x 510 x 632 mm 22,8 x 20,1 x 24,9 in
Shipping Weight	37,0 kg (81,6 lb)

DIMENSIONS

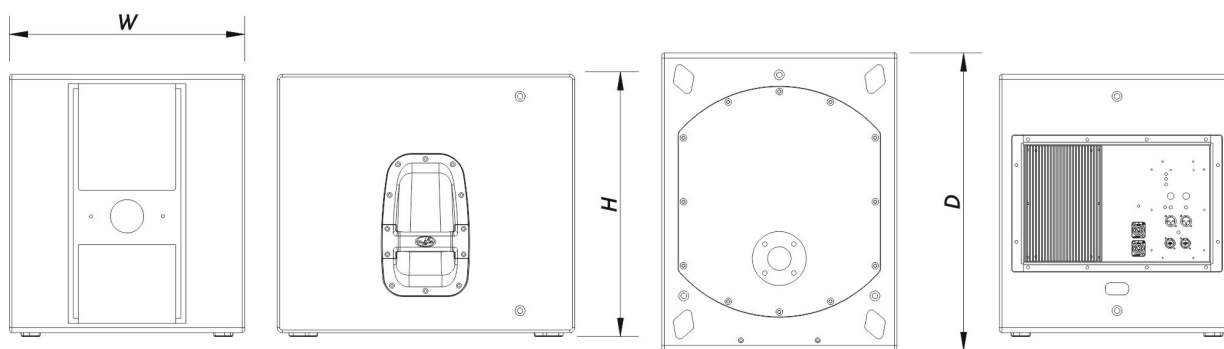

ORDERING INFORMATION

Model	Description	P/N
System		
ARTEC-S15A-W-230		10423740
Replacement Parts		
15LXN	Cone Transducer	10214360
DIGIMOD-1000 MASTER	Amplifier	30008238
DSP-ARTEC-S15A	Dsp	20406370

ARTEC-S15A-W-230

DAS Audio Group, S.L. - C/ Islas Baleares 24 - 46988
Fuente del Jarro - Valencia - Spain - Tel. +34961340860
Updated (DD/MM/YYYY): 13/10/2024



SOUND WITH SOUL

GM-15LX	Recone Kit	20208320
MP-ARTEC-S15A- 230	Power Module	30005286

Accessories

ANL-2	Rigging Accessories	10101020
TRD-6	Installation & Stacking Acc.	10104470

ARTEC-S15A-W-230

DAS Audio Group, S.L. - C/ Islas Baleares 24 - 46988
Fuente del Jarro - Valencia - Spain - Tel. +34961340860
Updated (DD/MM/YYYY): 13/10/2024



SOUND WITH SOUL