

# *Altea*<sup>400</sup>



## **ALTEA-408-T**

---

DAS Audio Group, S.L. - C/ Islas Baleares 24 - 46988  
Fuente del Jarro - Valencia - Spain - Tel. +34961340860  
Updated (DD/MM/YYYY): 08/11/2024



SOUND WITH SOUL

## KEY FEATURES

- 2-way, full range system
- 8" bass loudspeaker
- 1" compression driver
- Angled enclosure design for stage monitor use
- Built-in rigging points
- Stand mountable

## DESCRIPTION

ALTEA-408 is a passive system designed to offer exceptional sound quality in a wide variety of applications, from PA in small events, to stage monitor and fixed installations. Altea-408 is capable of reproducing frequencies from 70 Hz to 20 kHz and delivers a maximum SPL of 122 dB, making it an extremely versatile system.

The system features a powerful 8" transducer with 2" voice coil for the reproduction of mid and low frequencies. For the high frequencies, the system features a compression driver with a 1" voice coil, offering exceptional performance. This configuration ensures exceptional clarity and outstanding performance. The diffuser designed to provide a 90° x 90° dispersion guarantees together with the rest of the components a wide and uniform sound dispersion.

ALTEA-408 is made of high-quality polypropylene, making it an extremely rugged and lightweight system, weighing only 9.4 kg (20.7 lb). Equipped with integrated ergonomic handles and M8 rigging points, this system is easy to transport and install, offering a practical and efficient solution for any sound setup.

The ALTEA-408-T is a variant specifically designed for applications requiring connection to 70V/100V distributed audio systems, commonly used in commercial installations. It incorporates a high-quality built-in transformer that ensures optimal impedance matching, minimizing signal loss and distortion while providing electrical isolation.

# ALTEA-408-T

---

DAS Audio Group, S.L. - C/ Islas Baleares 24 - 46988  
Fuente del Jarro - Valencia - Spain - Tel. +34961340860  
Updated (DD/MM/YYYY): 08/11/2024



SOUND WITH SOUL

## SPECIFICATIONS

### Performance

Frequency Range (-10 dB)	70 Hz - 20 kHz
Horizontal Coverage (-6 dB)	90°
Vertical Coverage	90°
Nominal Impedance	8 ohms
Transformer Taps 70 V	12.5 W - 25 W - 50 W - 100 W
Transformer Taps 100 V	25 W - 50 W - 100 W
RMS Power Handling	150 W
Peak Power Handling	600 W
On-axis Sensitivity 1W/1 m	94 dB SPL
Maximum Peak SPL at 1 m	122 dB
Recommended Amplifier	INTEGRAL-A402 INTEGRAL-A1002 INTEGRAL-A1004

### Connectors

Audio Input Connector	Covered Barrier Strip Terminals
Audio Output Connector	Spring Terminals

### Enclosure

Enclosure Construction	Polypropylene
Enclosure Geometry	Trapezoidal
Rigging	M8 Rigging Points
Color	Black
Depth	260 mm (10,2 in)

# ALTEA-408-T

DAS Audio Group, S.L. - C/ Islas Baleares 24 - 46988  
Fuente del Jarro - Valencia - Spain - Tel. +34961340860  
Updated (DD/MM/YYYY): 08/11/2024



SOUND WITH SOUL

Dimensions ( H x W x D )	480 x 280 x 260 mm 18,9 x 11,0 x 10,2 in
--------------------------	---

Net Weight	8,5 kg ( 18,7 lb )
------------	--------------------

### Components

LF Driver	8GV
-----------	-----

HF Driver	M-32
-----------	------

### Shipping

Carton Dimensions ( H x W x D )	550 x 350 x 340 mm 21,6 x 13,8 x 13,4 in
---------------------------------	---

Shipping Weight	12,0 kg ( 26,5 lb )
-----------------	---------------------

### DIMENSIONS

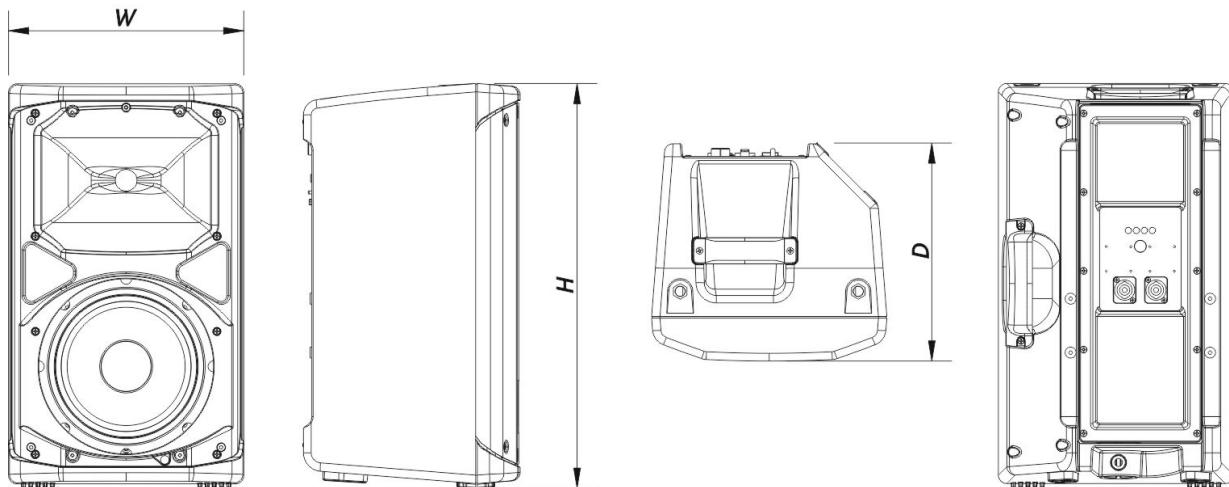

### ORDERING

Model	Description	P/N
-------	-------------	-----

# ALTEA-408-T

DAS Audio Group, S.L. - C/ Islas Baleares 24 - 46988  
Fuente del Jarro - Valencia - Spain - Tel. +34961340860  
Updated (DD/MM/YYYY): 08/11/2024



## INFORMATION

### System

---

ALTEA-408-T	10404992
-------------	----------

---

### Replacement Parts

---

8GV	Cone Transducer	20208984
-----	-----------------	----------

---

M-32	Compression Driver	20208970
------	--------------------	----------

---

TC-ALT408	Filter	20150100
-----------	--------	----------

---

### Accessories

---

ANL-1	Rigging Accessories	10101010
-------	---------------------	----------

---

ANL-1	Installation & Stacking Acc.	10101010
-------	------------------------------	----------

---

AX-112-5	Installation & Stacking Acc.	10102390
----------	------------------------------	----------

---

AXW-ALT	Installation & Stacking Acc.	10102391
---------	------------------------------	----------

---

FUN-AL408	Transport Accessories	10103782
-----------	-----------------------	----------

---

TRD-6	Installation & Stacking Acc.	10104470
-------	------------------------------	----------

---

TRD-7	Installation & Stacking Acc.	10104471
-------	------------------------------	----------

---

TRPD-S2-PAK	Installation & Stacking Acc.	10104011
-------------	------------------------------	----------

---

# ALTEA-408-T

---

DAS Audio Group, S.L. - C/ Islas Baleares 24 - 46988  
Fuente del Jarro - Valencia - Spain - Tel. +34961340860  
Updated (DD/MM/YYYY): 08/11/2024



SOUND WITH SOUL