

**artec 500 series**



## **ARTEC-S15A-230**

---

DAS Audio Group, S.L. - C/ Islas Baleares 24 - 46988  
Fuente del Jarro - Valencia - Spain - Tel. +34961340860  
Updated (DD/MM/YYYY): 13/10/2024



SOUND WITH SOUL

## KEY FEATURES

- Powered subwoofer system
- High output 15" loudspeaker
- Loop Thru connections
- Filtered output defeat switch
- Variable LPF range 100-138 Hz

## DESCRIPTION

The Artec-S15A is a powered subwoofer system designed to provide extended bass response for the Artec-full range cabinets. A 2000 Wpeak Class D amplifier drives a D.A.S. 15SX bass loudspeaker. The 15SX loudspeaker incorporates a 4" voice coil for high power handling and output. The subwoofer system includes two balanced inputs with stereo filtered output connections for Artec-satellite systems. The variable LPF ranges from 100 Hz 138 Hz.

# ARTEC-S15A-230

---

DAS Audio Group, S.L. - C/ Islas Baleares 24 - 46988  
Fuente del Jarro - Valencia - Spain - Tel. +34961340860  
Updated (DD/MM/YYYY): 13/10/2024



SOUND WITH SOUL

## SPECIFICATIONS

### Performance

Frequency Range (-10 dB)	45 Hz -138 Hz
--------------------------	---------------

Maximum Peak SPL at 1 m	134 dB
-------------------------	--------

### Electronics and Connectors

Nominal Amplifier Power (continuous)	1000 W
--------------------------------------	--------

Nominal Amplifier Power (peak)	2000 W
--------------------------------	--------

Input Type	Balanced
------------	----------

Input Impedance	20 kohms
-----------------	----------

Input Sensitivity	1.95 V (+8 dBu)
-------------------	-----------------

Audio Signal Input Connector	2 x Female XLR
------------------------------	----------------

Audio Signal Loop Thru Connector	2 x Male XLR
----------------------------------	--------------

AC Output Connector	powerCON NAC3FCB
---------------------	------------------

Current Draw 230 V / 115 V	2.0 A/-
----------------------------	---------

### Enclosure

Enclosure Construction	Birch Plywood
------------------------	---------------

Enclosure Geometry	Rectangular
--------------------	-------------

Rigging	M10 Rigging Points
---------	--------------------

Finish	ISO-flex Paint
--------	----------------

Color	Black
-------	-------

Dimensions ( H x W x D )	515 x 465 x 585 mm 20,3 x 18,3 x 23,0 in
--------------------------	---

Net Weight	31,0 kg ( 68,3 lb )
------------	---------------------

# ARTEC-S15A-230

DAS Audio Group, S.L. - C/ Islas Baleares 24 - 46988  
Fuente del Jarro - Valencia - Spain - Tel. +34961340860  
Updated (DD/MM/YYYY): 13/10/2024



SOUND WITH SOUL

## Components

LF Driver	15LXN
-----------	-------

## Shipping

Carton Dimensions ( H x W x D )	580 x 510 x 632 mm 22,8 x 20,1 x 24,9 in
Shipping Weight	37,0 kg ( 81,6 lb )

## DIMENSIONS

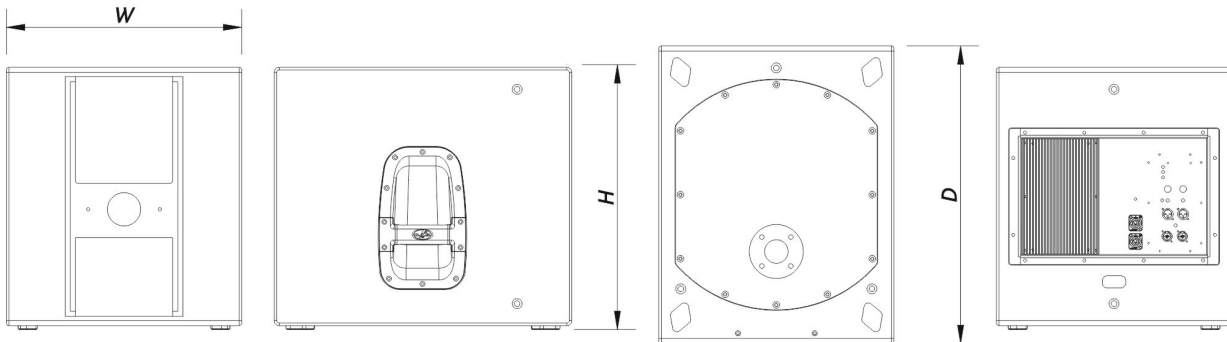

## ORDERING INFORMATION

Model	Description	P/N
-------	-------------	-----

### System

ARTEC-S15A-230		10423710
----------------	--	----------

### Replacement Parts

15LXN	Cone Transducer	10214360
DSP-ARTEC-S15A	Dsp	20406370
GM-15LX	Recone Kit	20208320

# ARTEC-S15A-230

DAS Audio Group, S.L. - C/ Islas Baleares 24 - 46988  
Fuente del Jarro - Valencia - Spain - Tel. +34961340860  
Updated (DD/MM/YYYY): 13/10/2024



MP-ARTEC-S15A- 230

Power Module

30005286

---

**Accessories**

---

ANL-2

Rigging Accessories

10101020

---

TRD-6

Installation & Stacking Acc.

10104470

---

# ARTEC-S15A-230

---

DAS Audio Group, S.L. - C/ Islas Baleares 24 - 46988

Fuente del Jarro - Valencia - Spain - Tel. +34961340860

Updated (DD/MM/YYYY): 13/10/2024



SOUND WITH SOUL